

TECHNICAL SPECIFICATION

COLOURS

BODY, FRONT, COUNTER TOP



31 CANADIAN OAK



67 WHITE PASTEL



106 LOWLAND NUT

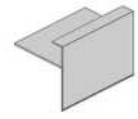

HPL ELEMENTS STRUCTURE



31 CANADIAN OAK



67 WHITE PASTEL



106 LOWLAND NUT

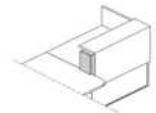
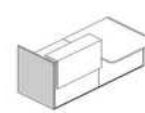

CORNER UNIT

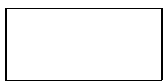

73 HIGH GLOSS  
WHITE



101 HIGH GLOSS  
BLACK



155 ANTHRACITE  
HIGH GLOSS

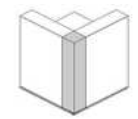

OPTIONAL TOP ELEMENT WITH LIGHT



73 HIGH GLOSS  
WHITE



WHITE, LACOBEL



101 HIGH GLOSS  
BLACK



BLACK, LACOBEL



155 ANTHRACITE  
HIGH GLOSS



ANTHRACITE,  
LACOBEL



SUPPORTING LEG WHERE WORKTOPS CONNECT NL41

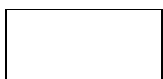

M015 WHITE  
SEMI-MATTE

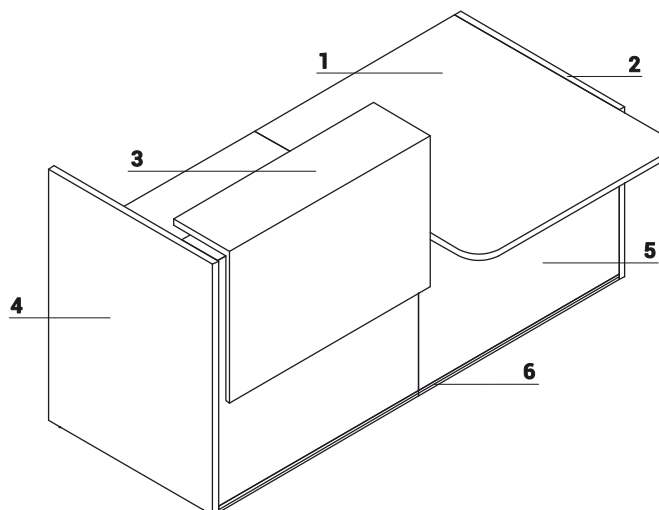

1. **Worktop** - MFC 1 1/8" | 28mm, PVC edge
2. **Low side panel** - MFC 1 1/8" | 28mm, PVC edge
3. **Optional top element with lightening** - top melamine board 1 1/8" | 28mm, front melamine board 6/8" | 18mm, all in HPL - gloss
4. **High side panel** - MFC 1 1/8" | 28mm, PVC edge
5. **Front** - MFC 6/8" | 18mm, PVC edge
6. **Decorative stripe** - PVC, colour: M009 - aluminum semi-matte

TECHNICAL SPECIFICATION

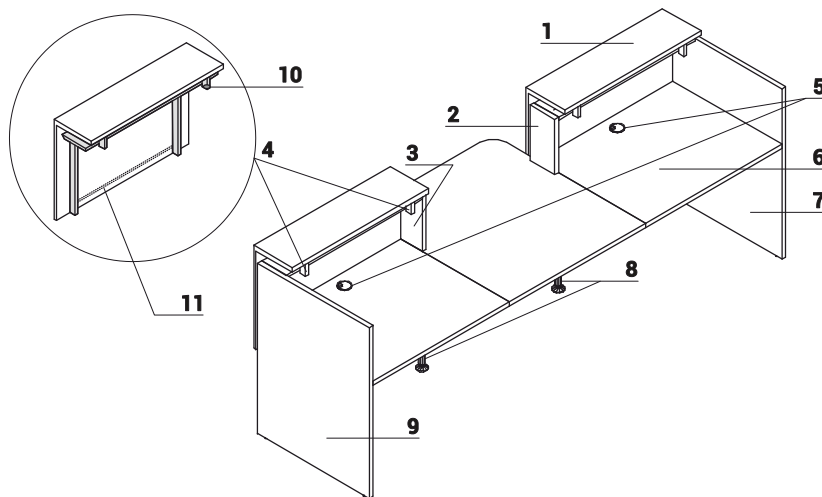

1. **Optional top element with lightening** - top melamine board 1 1/8" | 28mm, front melamine board 6/8" | 18mm, all in HPL - gloss
2. **Side panel linking low and heigh fronts** - MFC 1 1/8" | 28mm, PVC edge
3. **Side panel linking low and heigh fronts** - MFC 1 1/8" | 28mm, PVC edge
4. **Frame to optional top element with lightening** - metal powder-coated, white colour
5. **Cable grommets** - O3 1/8" | O80mm
6. **Worktop** - MFC 1 1/8" | 28mm, PVC edge
7. **High side panel** - MFC 1 1/8" | 28mm, PVC edge
8. **Supporting leg NE41**- required for connecting the tops
9. **High side panel** - MFC 1 1/8" | 28mm, PVC edge
10. Light switch
11. LED lighting – over the entire length of the extension, cold white (bluish kind of white)

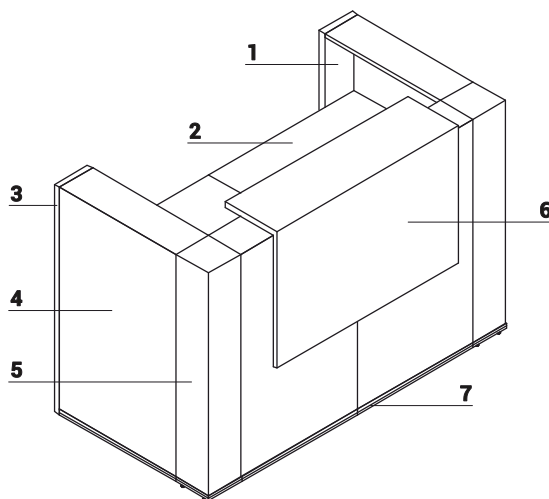

1. **High side panel** - MFC 1 1/8" | 28mm, PVC edge
2. **Worktop** - MFC 1 1/8" | 28mm, PVC edge
3. **High side panel** - MFC 1 1/8" | 28mm, PVC edge
4. **Front** - MFC 6/8" | 18mm, PVC edge
5. **Corner unit** - melamine board covered with HPL - gloss
6. **Optional top element with lightening** - top melamine board 1 1/8" | 28mm, front melamine board 6/8" | 18mm, all in HPL - gloss
7. **Decorative stripe** - PVC, colour: M009 - aluminum semi-matte

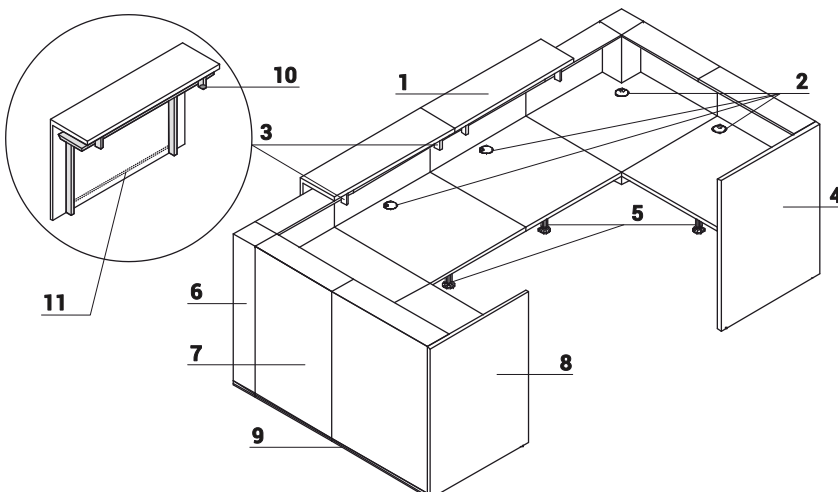

1. **Optional top element with lightening** - top melamine board 1 1/8" | 28mm, front melamine board 6/8" | 18mm, all in HPL - gloss
2. **Cable grommets** - O3 1/8" | O80mm
3. **Frame to optional top element with lightening** - metal powder-coated, white colour
4. **High side panel** - MFC 1 1/8" | 28mm, PVC edge
5. **Supporting leg NE41**- required for connecting the tops
6. **Corner unit** - melamine board covered with HPL - gloss
7. **Front** - MFC 6/8" | 18mm, PVC edge
8. **High side panel** - MFC 1 1/8" | 28mm, PVC edge
9. **Decorative stripe** - PVC, colour: M009 - aluminum semi-matte
10. Light switch
11. LED lighting – over the entire length of the extension, cold white (bluish kind of white)

TECHNICAL SPECIFICATION

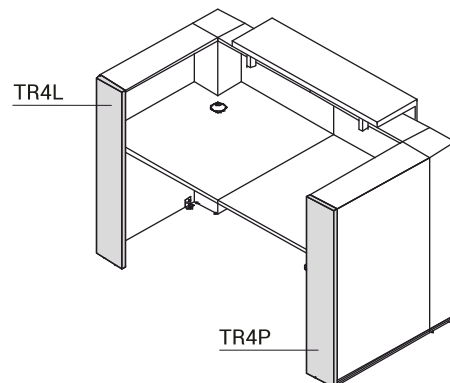
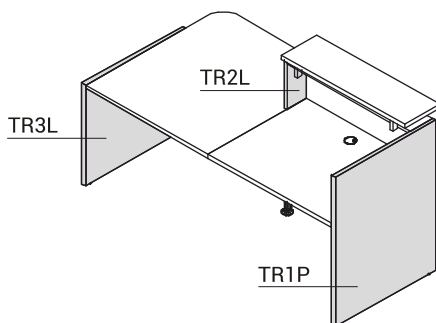
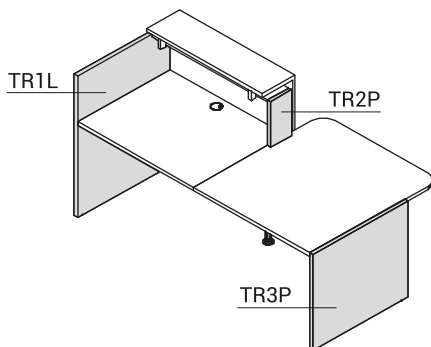

DIMENSIONS

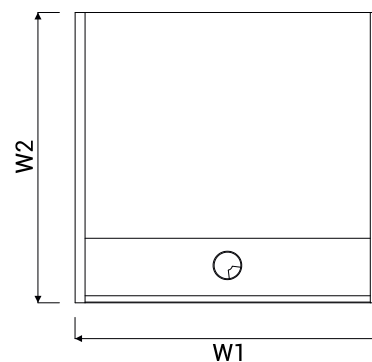
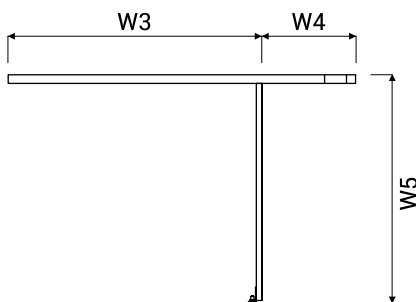
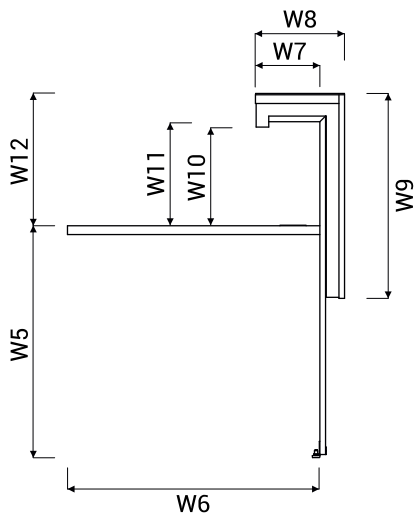

W1 - 33 6/8" 856mm | W2 - 32 2/8" 820mm | W3 - 32 2/8" 818mm | W4 - 11 7/8" 302mm | W5 - 29 1/8" 740mm | W6 - 31 4/8" 800mm | W7 - 8 1/8" 205mm  
 | W8 - 11 1/8" 282mm | W9 - 25 5/8" 650mm | W10 - 12 3/8" 315mm | W11 - 12 5/8" 322mm | W12 - 16 7/8" 419mm

RECEPTION DESKS SYSTEMS

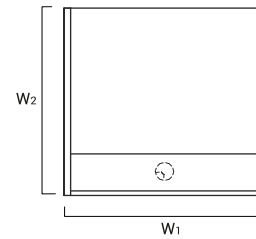
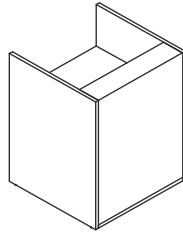

INDEX SYMBOL	DIMENSIONS					[mm]/[inch]	⚖️	📦	📦		COMPONENTS
	W <sub>1</sub>	W <sub>2</sub>	D <sub>1</sub>	D <sub>2</sub>	H						
<b>TRA13</b>	856 33 3/4"	820 32 1/4"	-	-	1090 42 7/8"		59.0	0.124	3		TR1L+TR08+TR1P

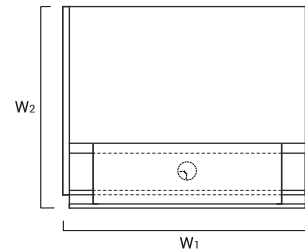
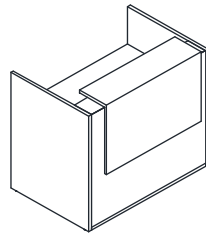

INDEX SYMBOL	DIMENSIONS					[mm]/[inch]	⚖️	📦	📦		COMPONENTS
	W <sub>1</sub>	W <sub>2</sub>	D <sub>1</sub>	D <sub>2</sub>	H						
<b>TRA14</b>	1056 41 5/8"	877 34 1/2"	-	-	1159 45 5/8"		83.0	0.320	4		TR1L+TR10+TR99+TR1P
<b>TRA15</b>	1256 49 1/2"	877 34 1/2"	-	-	1159 45 5/8"		87.0	0.332	4		TR1L+TR12+TR99+TR1P
<b>TRA16</b>	1456 57 3/8"	877 34 1/2"	-	-	1159 45 5/8"		89.0	0.344	4		TR1L+TR14+TR99+TR1P

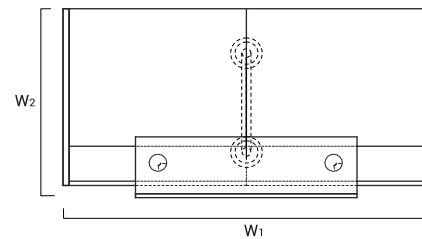
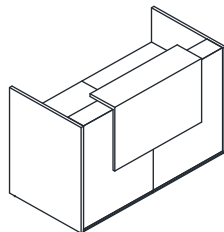

INDEX SYMBOL	DIMENSIONS					[mm]/[inch]	⚖️	📦	📦		COMPONENTS
	W <sub>1</sub>	W <sub>2</sub>	D <sub>1</sub>	D <sub>2</sub>	H						
<b>TRA17</b>	1656 65 1/4"	877 34 1/2"	-	-	1159 45 5/8"		103.0	0.425	6		TR1L+2xTR08+TR99+TR1P+NL41
<b>TRA18</b>	2056 81"	877 34 1/2"	-	-	1159 45 5/8"		117.0	0.449	6		TR1L+2xTR10+TR99+TR1P+NL41
<b>TRA19</b>	2456 96 3/4"	877 34 1/2"	-	-	1159 45 5/8"		125.0	0.473	6		TR1L+2xTR12+TR99+TR1P+NL41
<b>TRA20</b>	2856 112 1/2"	877 34 1/2"	-	-	1159 45 5/8"		129.0	0.498	6		TR1L+2xTR14+TR99+TR1P+NL41

DESCRIPTION

⚖️ - NET WEIGHT

📦 VOLUME

📦 NUMBER OF PACKAGES

RECEPTION DESKS SYSTEMS

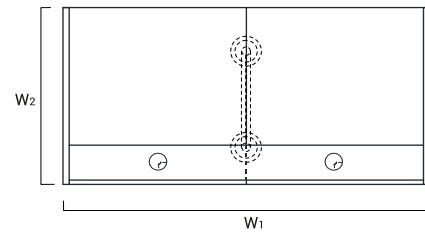
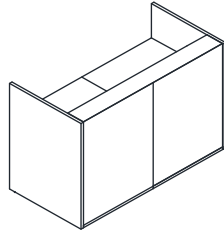

INDEX SYMBOL	DIMENSIONS					[mm]/[inch]	⚖️	📦	📦	COMPONENTS
	W <sub>1</sub>	W <sub>2</sub>	D <sub>1</sub>	D <sub>2</sub>	H					
<b>TRA117</b>	1656 65 1/4"	820 32 1/4"	-	-	1090 42 7/8"		86.0	0.242	5	TR1L+2xTR08+TR1P+NL41
<b>TRA118</b>	2056 81"	820 32 1/4"	-	-	1090 42 7/8"		100.0	0.266	5	TR1L+2xTR10+TR1P+NL41
<b>TRA119</b>	2456 96 3/4"	820 32 1/4"	-	-	1090 42 7/8"		108.0	0.290	5	TR1L+2xTR12+TR1P+NL41
<b>TRA120</b>	2856 112 1/2"	820 32 1/4"	-	-	1090 42 7/8"		112.0	0.314	5	TR1L+2xTR14+TR1P+NL41

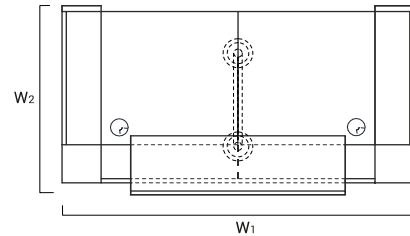
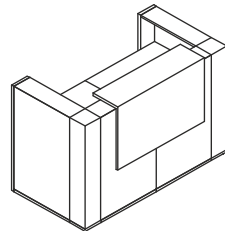

INDEX SYMBOL	DIMENSIONS					[mm]/[inch]	⚖️	📦	📦	COMPONENTS
	W <sub>1</sub>	W <sub>2</sub>	D <sub>1</sub>	D <sub>2</sub>	H					
<b>TRA42</b>	1640 64 5/8"	905 35 5/8"	-	-	1159 45 5/8"		99.0	0.460	8	TR4L+2xTR90+TR4P+TR99+NL41

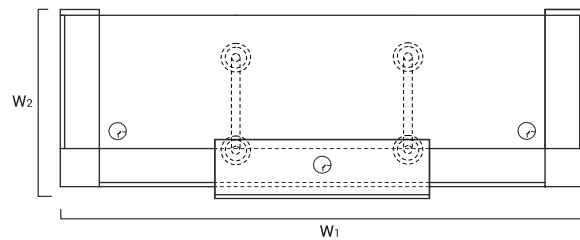
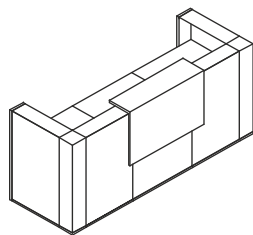

INDEX SYMBOL	DIMENSIONS					[mm]/[inch]	⚖️	📦	📦	COMPONENTS
	W <sub>1</sub>	W <sub>2</sub>	D <sub>1</sub>	D <sub>2</sub>	H					
<b>TRA21</b>	2440 96 1/8"	905 35 5/8"	-	-	1159 45 5/8"		126.0	0.577	10	TR4L+2xTR90+TR08+TR4P+TR99+2xNL41
<b>TRA22</b>	2640 103 7/8"	905 35 5/8"	-	-	1159 45 5/8"		133.0	0.590	10	TR4L+2xTR90+TR10+TR4P+TR99+2xNL41
<b>TRA23</b>	2840 111 3/4"	905 35 5/8"	-	-	1159 45 5/8"		137.0	0.602	10	TR4L+2xTR90+TR12+TR4P+TR99+2xNL41
<b>TRA24</b>	3040 119 5/8"	905 35 5/8"	-	-	1159 45 5/8"		139.0	0.614	10	TR4L+2xTR90+TR14+TR4P+TR99+2xNL41

DESCRIPTION

⚖️ - NET WEIGHT

📦 VOLUME

📦 NUMBER OF PACKAGES

RECEPTION DESKS SYSTEMS

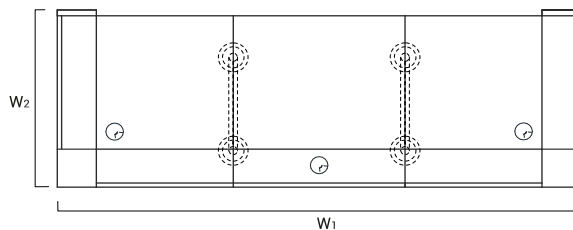
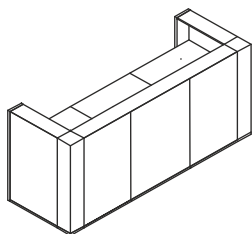

INDEX SYMBOL	DIMENSIONS					[mm]/[inch]	⚖️	📦	📦		COMPONENTS
	W <sub>1</sub>	W <sub>2</sub>	D <sub>1</sub>	D <sub>2</sub>	H						
<b>TRA121</b>	2440 96 1/8"	848 33 3/8"	-	-	1090 42 7/8"		109.0	0.394	9		TR4L+2xTR90+TR08+TR4P +2xNL41
<b>TRA122</b>	2640 103 7/8"	848 33 3/8"	-	-	1090 42 7/8"		116.0	0.406	9		TR4L+2xTR90+TR10+TR4P +2xNL41
<b>TRA123</b>	2840 111 3/4"	848 33 3/8"	-	-	1090 42 7/8"		120.0	0.418	9		TR4L+2xTR90+TR12+TR4P +2xNL41
<b>TRA124</b>	3040 119 5/8"	848 33 3/8"	-	-	1090 42 7/8"		122.0	0.430	9		TR4L+2xTR90+TR14+TR4P +2xNL41

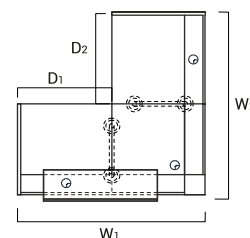
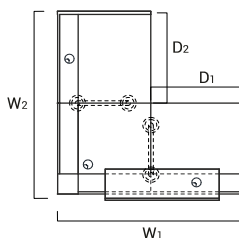
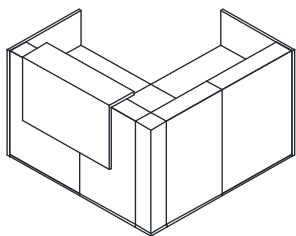

INDEX SYMBOL	DIMENSIONS					[mm]/[inch]	⚖️	📦	📦		COMPONENTS
	W <sub>1</sub>	W <sub>2</sub>	D <sub>1</sub>	D <sub>2</sub>	H						
<b>TRA25</b>	1648 64 7/8"	1705 67 1/8"	-	-	1159 45 5/8"		141.0	0.586	9		TR1L+TR08+TR90+TR08+TR1P +TR99+2xNL41
<b>TRA26</b>	1848 72 3/4"	1705 67 1/8"	-	-	1159 45 5/8"		148.0	0.598	9		TR1L+TR08+TR90+TR10+TR1P +TR99+2xNL41
<b>TRA27</b>	2048 80 5/8"	1705 67 1/8"	-	-	1159 45 5/8"		152.0	0.611	9		TR1L+TR08+TR90+TR12+TR1P +TR99+2xNL41
<b>TRA28</b>	2248 88 1/2"	1705 67 1/8"	-	-	1159 45 5/8"		154.0	0.623	9		TR1L+TR08+TR90+TR14+TR1P +TR99+2xNL41

DESCRIPTION

⚖️ - NET WEIGHT

📦 VOLUME

📦 NUMBER OF PACKAGES

RECEPTION DESKS SYSTEMS

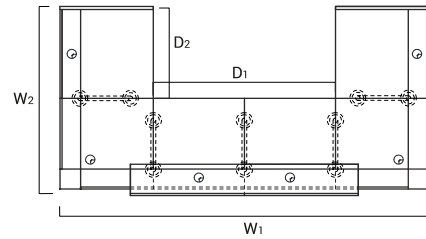
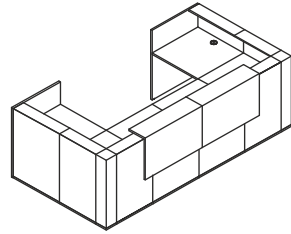

INDEX SYMBOL	DIMENSIONS					[mm]/[inch]	⚖️	📦	📦	COMPONENTS
	W <sub>1</sub>	W <sub>2</sub>	D <sub>1</sub>	D <sub>2</sub>	H					
<b>TRA29</b>	3240 127 1/2"	1705 67 1/8"	-	-	1159 45 5/8"		250.0	1.166	17	TR1L+2xTR08+2xTR90+2xTR08 +TR1P+2xTR99+5xNL41
<b>TRA30</b>	3640 143 1/4"	1705 67 1/8"	-	-	1159 45 5/8"		264.0	1.190	17	TR1L+2xTR08+2xTR90+2xTR10 +TR1P+2xTR99+5xNL41
<b>TRA31</b>	4040 159"	1705 67 1/8"	-	-	1159 45 5/8"		272.0	1.214	17	TR1L+2xTR08+2xTR90+2xTR12 +TR1P+2xTR99+5xNL41
<b>TRA32</b>	4440 174 3/4"	1705 67 1/8"	-	-	1159 45 5/8"		276.0	1.239	17	TR1L+2xTR08+2xTR90+2xTR14 +TR1P+2xTR99+5xNL41

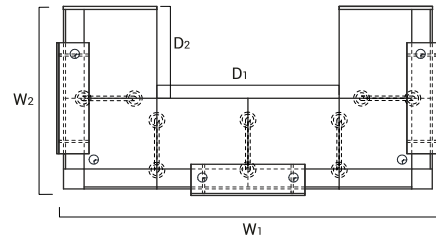
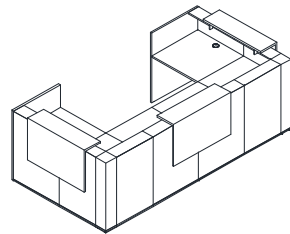

INDEX SYMBOL	DIMENSIONS					[mm]/[inch]	⚖️	📦	📦	COMPONENTS
	W <sub>1</sub>	W <sub>2</sub>	D <sub>1</sub>	D <sub>2</sub>	H					
<b>TRA129</b>	3354 132"	1705 67 1/8"	-	-	1159 45 5/8"		267.0	1.349	18	TR1L+2xTR08+2xTR90+2xTR08 +TR1P+3xTR99+5xNL41
<b>TRA130</b>	3754 147 3/4"	1705 67 1/8"	-	-	1159 45 5/8"		281.0	1.374	18	TR1L+2xTR08+2xTR90+2xTR10 +TR1P+3xTR99+5xNL41
<b>TRA131</b>	4154 163 1/2"	1705 67 1/8"	-	-	1159 45 5/8"		289.0	1.398	18	TR1L+2xTR08+2xTR90+2xTR12 +TR1P+3xTR99+5xNL41
<b>TRA132</b>	4554 179 1/4"	1705 67 1/8"	-	-	1159 45 5/8"		293.0	1.422	18	TR1L+2xTR08+2xTR90+2xTR14 +TR1P+3xTR99+5xNL41

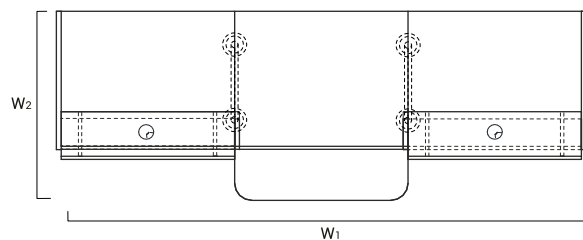
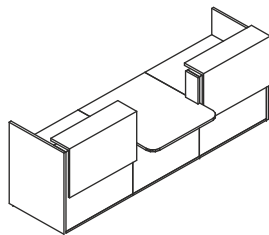

INDEX SYMBOL	DIMENSIONS					[mm]/[inch]	⚖️	📦	📦	COMPONENTS
	W <sub>1</sub>	W <sub>2</sub>	D <sub>1</sub>	D <sub>2</sub>	H					
<b>TRA33</b>	3056 120 3/8"	1120 44 1/8"	-	-	1159 45 5/8"		169.0	0.793	11	TR1L+TR10+TR2P+TR11+TR2L +TR10+TR1P+2xTR99+2xNL41
<b>TRA34</b>	3456 136 1/8"	1120 44 1/8"	-	-	1159 45 5/8"		177.0	0.817	11	TR1L+TR12+TR2P+TR11+TR2L +TR12+TR1P+2xTR99+2xNL41
<b>TRA35</b>	3856 151 3/4"	1120 44 1/8"	-	-	1159 45 5/8"		181.0	0.841	11	TR1L+TR14+TR2P+TR11+TR2L +TR14+TR1P+2xTR99+2xNL41

DESCRIPTION

⚖️ - NET WEIGHT

📦 VOLUME

📦 NUMBER OF PACKAGES

RECEPTION DESKS SYSTEMS

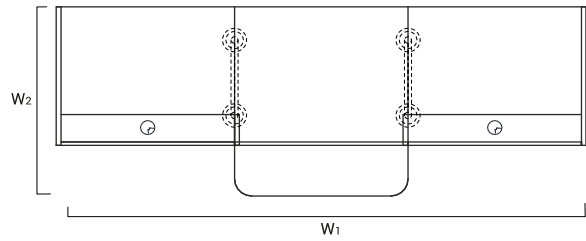
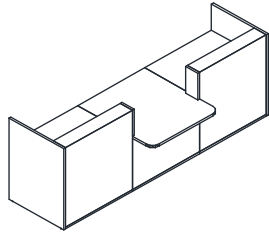

INDEX SYMBOL	DIMENSIONS					[mm]/[inch]	⚖️	📦	📦		COMPONENTS
	W <sub>1</sub>	W <sub>2</sub>	D <sub>1</sub>	D <sub>2</sub>	H						
<b>TRA133</b>	3056 120 3/8"	1120 44 1/8"	-	-	1090 42 7/8"		135.0	0.426	9		TR12+TR10+TR2P+TR11+TR2L +TR10+TR1P+2xNL41
<b>TRA134</b>	3456 136 1/8"	1120 44 1/8"	-	-	1090 42 7/8"		143.0	0.451	9		TR12+TR12+TR2P+TR11+TR2L +TR12+TR1P+2xNL41
<b>TRA135</b>	3856 151 3/4"	1120 44 1/8"	-	-	1090 42 7/8"		147.0	0.475	9		TR12+TR14+TR2P+TR11+TR2L +TR14+TR1P+2xNL41

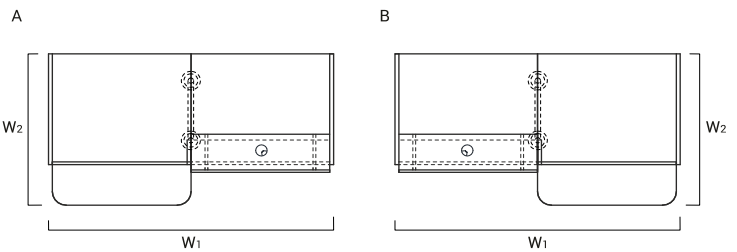
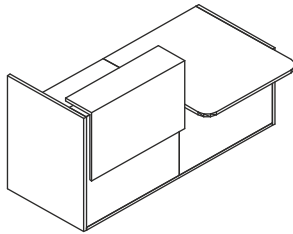

INDEX SYMBOL	DIMENSIONS					[mm]/[inch]	⚖️	📦	📦		COMPONENTS
	W <sub>1</sub>	W <sub>2</sub>	D <sub>1</sub>	D <sub>2</sub>	H						
A <b>TRA36L</b>	2056 81"	1120 44 1/8"	-	-	1159 45 5/8"		111.5	0.467	7		TR1L+TR10+TR2P+TR11+TR3P +TR99+NL41
B <b>TRA36P</b>	2056 81"	1120 44 1/8"	-	-	1159 45 5/8"		111.5	0.467	7		TR3L+TR11+TR2L+TR10+TR1P +TR99+NL41
A <b>TRA37L</b>	2256 88 7/8"	1120 44 1/8"	-	-	1159 45 5/8"		115.5	0.479	7		TR1L+TR12+TR2P+TR11+TR3P +TR99+NL41
B <b>TRA37P</b>	2256 88 7/8"	1120 44 1/8"	-	-	1159 45 5/8"		115.5	0.479	7		TR3L+TR11+TR2L+TR12+TR1P +TR99+NL41
A <b>TRA38L</b>	2456 96 3/4"	1120 44 1/8"	-	-	1159 45 5/8"		117.5	0.491	7		TR1L+TR14+TR2P+TR11+TR3P +TR99+NL41
B <b>TRA38P</b>	2456 96 3/4"	1120 44 1/8"	-	-	1159 45 5/8"		117.5	0.492	7		TR3L+TR11+TR2L+TR14+TR1P +TR99+NL41

DESCRIPTION

⚖️ - NET WEIGHT

📦 VOLUME

📦 NUMBER OF PACKAGES



RECEPTION DESKS SYSTEMS

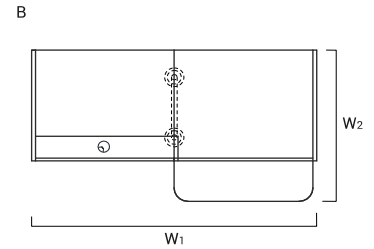
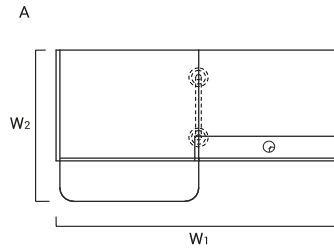
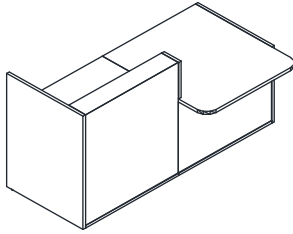

INDEX SYMBOL	DIMENSIONS [mm]/[inch]						⚖️ kg	📦 m3	📦 pcs		COMPONENTS
	W <sub>1</sub>	W <sub>2</sub>	D <sub>1</sub>	D <sub>2</sub>	H						
A <b>TRA136L</b>	2056 81"	1120 44 1/8"	-	-	1090 42 7/8"		94.5	0.283	6		TR1L+TR10+TR2P+TR11+TR3P+NL41
B <b>TRA136P</b>	2056 81"	1120 44 1/8"	-	-	1090 42 7/8"		94.5	0.284	6		TR3L+TR11+TR2L+TR10+TR1P+NL41
A <b>TRA137L</b>	2256 88 7/8"	1120 44 1/8"	-	-	1090 42 7/8"		98.5	0.295	6		TR1L+TR12+TR2P+TR11+TR3P+NL41
B <b>TRA137P</b>	2256 88 7/8"	1120 44 1/8"	-	-	1090 42 7/8"		98.5	0.296	6		TR3L+TR11+TR2L+TR12+TR1P+NL41
A <b>TRA138L</b>	2456 96 3/4"	1120 44 1/8"	-	-	1090 42 7/8"		100.5	0.308	6		TR1L+TR14+TR2P+TR11+TR3P+NL41
B <b>TRA138P</b>	2456 96 3/4"	1120 44 1/8"	-	-	1090 42 7/8"		100.5	0.308	6		TR3L+TR11+TR2L+TR14+TR1P+NL41

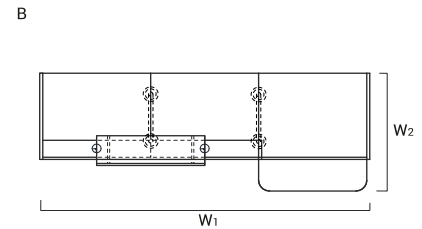
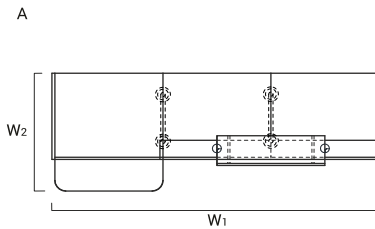
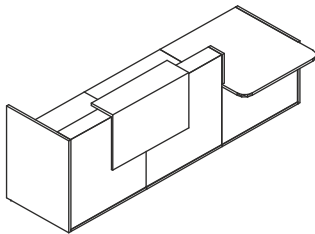



INDEX SYMBOL	DIMENSIONS [mm]/[inch]						⚖️ kg	📦 m3	📦 pcs		COMPONENTS
	W <sub>1</sub>	W <sub>2</sub>	D <sub>1</sub>	D <sub>2</sub>	H						
A <b>TRA39L</b>	3056 120 3/8"	1120 44 1/8"	-	-	1159 45 5/8"		145.5	0.596	9		TR1L+2xTR10+TR2P+TR11+TR3P+TR99+2xNL41
B <b>TRA39P</b>	3056 120 3/8"	1120 44 1/8"	-	-	1159 45 5/8"		145.5	0.597	9		TR3L+TR11+TR2L+2xTR10+TR1P+TR99+2xNL41
A <b>TRA40L</b>	3456 136 1/8"	1120 44 1/8"	-	-	1159 45 5/8"		153.5	0.620	9		TR1L+2xTR12+TR2P+TR11+TR3P+TR99+2xNL41
B <b>TRA40P</b>	3456 136 1/8"	1120 44 1/8"	-	-	1159 45 5/8"		153.5	0.621	9		TR3L+TR11+TR2L+2xTR12+TR1P+TR99+2xNL41
A <b>TRA41L</b>	3856 151 3/4"	1120 44 1/8"	-	-	1159 45 5/8"		157.5	0.645	9		TR1L+2xTR14+TR2P+TR11+TR3P+TR99+2xNL41
B <b>TRA41P</b>	3856 151 3/4"	1120 44 1/8"	-	-	1159 45 5/8"		157.5	0.645	9		TR3L+TR11+TR2L+2xTR14+TR1P+TR99+2xNL41

DESCRIPTION









⚖️ - NET WEIGHT

📦 VOLUME

📦 NUMBER OF PACKAGES

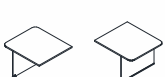
PRODUCT ILLUSTRATION	DIMENSIONS [mm]/[inch]			INDEX SYMBOL						COMPONENTS
	WIDTH	DEPTH	HEIGHT			kg	m3	pcs		

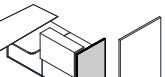
COMPOSITION ELEMENTS

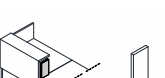
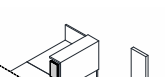

	800 31 1/2"	818 32 1/4"	1090 42 7/8"	TR08		25.0	0.054	1		
	1000 39 3/8"	818 32 1/4"	1090 42 7/8"	TR10		32.0	0.067	1		
	1200 47 1/4"	818 32 1/4"	1090 42 7/8"	TR12		36.0	0.079	1		
	1400 55 1/8"	818 32 1/4"	1090 42 7/8"	TR14		38.0	0.091	1		
	818 32 1/4"	818 32 1/4"	1090 42 7/8"	TR90		36.0	0.098	2		
	1000 39 3/8"	1120 44 1/8"	740 29 1/8"	TR11		30.0	0.092	1		
	1000 39 3/8"	282 11 1/8"	650 25 5/8"	TR99		17.0	0.183	1		decorative lighted element
	28 1 1/8"	820 32 1/4"	1090 42 7/8"	TR1L		17.0	0.035	1		side panel for high units - left
	28 1 1/8"	820 32 1/4"	1090 42 7/8"	TR1P		17.0	0.035	1		side panel for high units - right
	28 1 1/8"	182 7 1/8"	350 13 3/4"	TR2L		1.5	0.003	1		left upper side panel for combining low and high element
	28 1 1/8"	182 7 1/8"	350 13 3/4"	TR2P		1.5	0.003	1		right upper side panel for combining low and high element

DESCRIPTION



 - NET WEIGHT

 VOLUME

 NUMBER OF PACKAGES

PRODUCT ILLUSTRATION	DIMENSIONS [mm]/[inch]			INDEX SYMBOL						COMPONENTS
	WIDTH	DEPTH	HEIGHT			kg	m3	pcs		

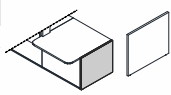
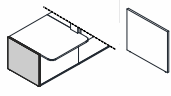
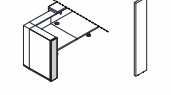
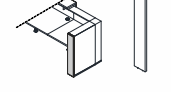
**COMPOSITION ELEMENTS**

	28 1 1/8"	820 32 1/4"	740 29 1/8"	<b>TR3L</b>		12.0	0.025	1		left side panel for low unit
	28 1 1/8"	820 32 1/4"	740 29 1/8"	<b>TR3P</b>		12.0	0.025	1		right side panel for low unit
	28 1 1/8"	182 7 1/8"	1090 42 7/8"	<b>TR4L</b>		4.0	0.008	1		side panel for high units - left
	28 1 1/8"	182 7 1/8"	1090 42 7/8"	<b>TR4P</b>		4.0	0.008	1		side panel for high units - right
	585 23"	142 5 5/8"	712 28"	<b>NL41</b>		2.0	0.063	1		round profile leg

DESCRIPTION

 - NET WEIGHT

 VOLUME

 NUMBER OF PACKAGES